

Nailing the Hot Water & Heating Systems in High Performance Homes: One Builder's Research Project

Martha Rose ¹

Introduction:

In 2005, Martha Rose Construction Inc. (MRC) upgraded the specs in their Built Green Certified homes to include high performance and healthy home features. In 2007, MRC joined the Department of Energy's Builders Challenge Program. Less than 1% of the market builders in the country work under this umbrella, which has a tag line "Research Towards Net Zero". It charges its builders with striving to reach net zero, while still being replicable and affordable. A recent name change better illustrates the goal: "DOE Zero Energy Ready Home".

With the help of the mechanical engineers that work with DOE on this program, Martha Rose Construction began trying different space and hot water heating combinations. The projects the company undertakes are small by development standards and they are custom designed for each site, even though they are sold on the speculative market place after completion.

The goal was and still is, to find the magic bullet for water and space heating that combine affordability with efficiency and practicality. When the calculated heat loads are extremely low due to super insulation, air sealing, and heat recovery ventilation (HRV), it no longer makes monetary sense to have a fancy heating system. The Building America engineers promote the KISS (keep it simple stupid) concept!

In this article, we will look at the factors that led Martha Rose Construction to try different heating types and the level of builder and buyer satisfaction with each combination. Four projects' mechanical systems will be reviewed and we will end with what is likely the best recommendation going forward for a high performance home.

Key Words: Built Green, High Performance Home, Airtight Homes, Comfort, HRV system, Certified, Net Zero, Healthy Home

Goal:

Martha Rose Construction (MRC) wished to be a leader in building energy efficient homes for the speculative market in the Seattle area. Pushing the boundaries of energy efficiency in the speculative home marketplace creates a shift in how new homes are built because speculative home builders are a competitive breed. Marketing these homes properly sets them apart and insures that they will stand out and sell more quickly, especially in a downturn or when energy prices begin to rise dramatically. As other developers catch on, they too will push the energy efficiency envelope and help transform the marketplace.

¹ President, Martha Rose Construction www.MarthaRoseConstruction.com and current president of the Master Builders Association of King and Snohomish Counties. www.mbs-ks.com

The author is a builder in the Seattle marketplace, and has made a career in the construction industry for over 41 years.

Overview and Strategy:

The owner of MRC had an interest in conservation since the late 1970's, so it was easy to embrace the Master Builders Association, Built Green program and the marketing edge it would give the company. This local Green Building Program was created in 2000, as the result of public, private and non-profit collaboration. Later, NAHB would model their National Green Building certification after the MBA's Built Green certifications. These two programs focus primarily on single family homes, duplexes and townhomes. They are structured a bit differently from LEED for Homes, but are every bit as rigorous.

Since 2003, Martha Rose Construction has received much attention from all forms of the media as an early adopter of sustainable building practices including energy efficiency and healthy homes in the Seattle area. Some of the construction techniques that were featured in the articles, were the addition of solar panels to many of the roofs, the implementation of low impact development techniques, and the installation of high efficiency heat recovery ventilation systems in all of the homes.

Part of the motivation to change the way we build came from the owner's sensitivities to chemicals, which came to light in early 2000. Too many years of working in the construction industry around noxious off-gassing and VOC's, made it impossible for the owner to even walk into a new home without a reaction. Healthy Home training and lots of research started lighting the way to making better material and equipment choices.

Queen City Eco Village – sold in 2008

A small community with (4) new lots and 7 dwelling units were built on a one acre parcel that contained the original farmhouse from the Queen City Poultry Ranch. A decision was made to save the 1904 structure and construct 3 new homes around it with carriage houses above the detached garages. A renovation that would both preserve and enhance the old structure, would bring it up to the current WA State Energy Code in effect in 2008, and save all of the charm of the original home.

The new homes were built with an insulation package that includes a wall assembly using fiberglass BIB's (blown-in-batts) and foam sheathing under the exterior plywood, for an R-26 value. The roof and attic assembly contains R-60 blown-in fiberglass, and under the slab is a single layer of R-10 closed cell foam. The triple glazed windows and fiberglass doors have a .25 U value and the blower door test showed less than 2 air changes per hour at 50 pascals (ACH@50p). The heat load calculations predicted a need for a 12,000 BTU's furnace.

There was good solar access and the market was booming, so the architectural designs included roofs that could handle both solar hot water and Photovoltaics (PV). MRC had been using hot water radiators for space heating in the last several projects after learning that forced air heat was not ideal for a healthy home. While the radiators had been used for at least 4 sites, the method of heating the water was adjusted on this project.

The mechanical subcontractor recommended a strategy that uses the same equipment for domestic hot water and the radiators: a Trinity on-demand boiler coupled with a storage tank for the solar. Evacuated tubes are installed on the roof of each home. A pump circulates the water in the storage tank up to the collectors when there is a temperature differential of around 12 degrees. The circulation stops when there is a 5 degree difference between the rooftop solar and the water in the tank. A call for heat in the radiator system triggers a different pump to come on that is in line with the radiator piping. It circulates the

water to all of the radiators throughout the home until the heat demand is satisfied. Domestic hot water also pulls from the same storage tank.

In summary, this assembly of equipment: the solar hot water on the roof, the on-demand boiler and the 80 gallon storage tank provide hot water for a 4 bedroom household plus a one-bedroom carriage house. While many aspects of this system work fine, there is an inherent problem with it, in that, the way it was installed prevents maximum efficiency. Instead of the solar pre-heating the water, the boiler does this. While this is counter intuitive, the heating contractor swore by his methods citing his own home as an example. The Building America engineers used a data monitor for one year to measure the energy savings from the solar hot water and were surprised that it performed better than they thought it would.

Other components in each new home help to complete the energy efficiency package. A 92% efficient Fantech 3005R HRV system runs on low speed delivering 5 complete filtered air changes a day. Fresh air is delivered to each bedroom and living room as stale air is pulled from all wet locations: bathrooms, utility room and kitchen. Heat from the outgoing air stream warms up the incoming air so that it feels neutral to the occupants of the home.



Inside the Fantech 3005R HRV with two heat exchange cores.



HRV sound control measures: flex pipe at the machine and suspended from ceiling (photo above)

To lower electricity bills, a grid-tied photovoltaic system on each new home generates about 3500 kilowatt hours a year and all of the lighting uses florescent bulbs.

Major appliances are gas and a HeatnGlo “Paloma” 80% efficient gas freestanding fireplace graces the living room. It’s rated for around 25,000 btu’s and is capable of heating the entire home without support from the hot water radiator system. There is 100% satisfaction with the gas free-standing fireplace and one owner used it exclusively all winter as the only heat source with excellent results.

The final HERS (Home Energy Performance Rating) score for each of the three new homes is 31. A score of zero is the goal, but any score under 70 is considered excellent.

As you will see, in the next examples, we will not replicate the solar hot water heating system used on this project, nor will we recommend it to other builders. As the homeowner of one of the three new homes in Queen City EcoVillage, I am prepared to eventually modify the hot water system to a simpler and more efficient package.

Fish Singer Place – sold in 2010

This (4) lot, 5-home community is comprised of a 1920’s renovated farmhouse and 4 new homes, one of which is a carriage house. Our insulation standards went up a couple notches to get closer to the standard called Passive Haus.

Here is the breakdown: walls now have an R-28 value, attic is R-60, under-floor slab has a double layer of foam, rated an R-20, and windows are quadruple glazed with insulated fiberglass frames. Blower door test showed air infiltration at less than 2 ACH@50 pascals. As

usual, the architect took advantage of solar orientation. The heat load calcs predicted a need for a 9,000 btu furnace.

After consultation with the Building America mechanical engineers, a decision was made to try the new Mantis 93% efficiency gas fireplace as the primary heat source for each home. Coupled with the Fantech HRV running 24/7, we reasoned that even without heating ductwork, the house would stay evenly warm. The pro's of the Mantis are this: it is made in the US (Ohio) by Empire Industries, a long established furnace manufacturing firm. The technology was created in Australia and perfected here about 8 years ago. We may have been their first project to use this furnace in a speculative home as the primary heat source.

Each home has 3 to 4 bedrooms and a decision was made to install nominal baseboard heaters in each bedroom as a security blanket for the homeowners, with the understanding that the likelihood of ever turning them on was zero. Electric in-floor heating mats were used in all of the bathrooms, as well.

At first, when the fireplace units were turned on, they "growled" when the fan came on. Several reps from the factory came out from Ohio, and the technician replaced the part that was making the noise. They were interested in getting this right because of the market potential of the Mantis for high performance home builders.



The Mantis – a high efficiency gas furnace disguised as a free-standing fireplace.

I cannot think of any downside to the use of these furnaces that double as a fireplace, as long as the home is planned for gas and a high efficiency HRV system is used that runs 24/7. All of the buyers have expressed a high level of satisfaction with their comfort level within the home. The initial noise problem was solved and the homeowners are unaware that it was ever an issue.

For heating domestic hot water we chose the new 50 gallon gas hot water heater by A.O.Smith called the Vertex. The company collaborated with the Department of Energy to come up with this 95% efficient hot water heater. It is designed to never run out of hot water. On the farmhouse, we also installed a solar hot water flat plate collector with a solar hot water storage tank. This simple solar hot water system preheats the incoming cold water before the Vertex raises the temp to 120 degrees or so. The family of four that lives in this home is very pleased with their extremely low gas bills.



Solar Hot Water Storage paired with AO Smith Vertex Hot Water Tank



Two flat plate hot water collectors provide much of the hot water for a family of four.

Because these homes were built in the midst of the recession, photovoltaics were not installed on the roofs, just the conduits to allow for the future install of such a system. Our HERS score was right around 50 on the new homes and 37 on the old farmhouse.



Summer Solstice Shadow Lines on June 21.

In homes that are plumbed for gas and use HRV ventilation, both the Mantis fireplace and the Vertex hot water heaters make excellent choices for energy efficient heating. The electric in-floor heating mats in the bathrooms turned out to be unnecessary due to the overall even temperature of the homes.

City Cabins on Queen Anne – sold in 2012

This is an in-City lot on the West side of Queen Anne Hill with views of Fisherman's Terminal, the Olympics and bits of Puget Sound. A duplex was deconstructed, the foundation reinforced and two townhomes put back.

The insulation was modified from the prior project to include R-30 walls, R-30 under the slab, R-60 attic and quadruple paned windows. The Heat Load calcs said we would need to use 10,000 btu's to heat the homes.

In 2011, Martha Rose Construction made a decision to stop using gas in all new homes. The reasons are fourfold: (1) Homes that use gas are not as healthy. (2) High performance homes use so little energy that the base fees on the utility bills often exceed the consumption. By eliminating one utility, we can provide even lower utility bills for the customers. (3) We don't want to participate in fracking anymore. (4) By going all-electric, the door is opened to someday having all power come from renewables.

This change of direction necessitated another shift in equipment choices. Again, we turned to our trusted Building America Team for advice. For this project, we settled on the Mitsubishi 4 head ductless mini-splits. A head was installed in the main living area and then one in each of the three bedrooms. There was no heat installed in the bathrooms. Several

factors influenced the decision to go with the four-head heat pump instead of just installing a single head in the living room and supplementing with small electric unit heaters in the bedroom. The façade of the two units faces west and has higher potential for overheating. The neighborhood is more upscale and the buyer would likely feel more secure with the air conditioning option the heat pump system provides.

The buyers like the heating and cooling aspect of the mini-splits. The second year required a service call for one unit. The owners were advised to set up a maintenance contract with the heating company to prevent loss of heat during cold weather. One of the next door neighbors repeatedly complained that the heat pump noise kept them awake at night. We had built a double fence with foam in between to help buffer the noise, but the tallness of both structures created a canyon effect that magnified the noise. After some research, I found a sound absorption product made from recycled plastic. It is immune from rain and other weather. We were able to install it as a sloped “roof” over the equipment so that half of the noise would be absorbed and half of it would be deflected out toward the street. There have been no more complaints from the neighbors since installing this material.

The new AirTap heat pump hot water heater was chosen for its high performance ratings and the ability to duct the cold air that it produces, to the outdoors. Because this site is on a hillside, half of the building’s footprint became a conditioned crawl space with 1000 cubic feet of area and enough headroom for the 50 gallon water tank. One supply vent from the HRV system was ducted into the insulated conditioned space to make sure that the temperature would stay in the 60’s to keep the heat pump working at optimum efficiency. The fan on the AirTap draws 350 cfm’s. A building verifier asked about the impact of that on an airtight house and asked if it would create negative pressure in the home. An Air Generate technical rep thought it would be fine and suggested that some of the makeup air would come from the exterior because the crawl space was not as air tight as the rest of the home. Some of the air would come from the HRV as well.



Heat Pump Hot Water Heater with duct bringing cold air to the exterior

The installation needs of an AirTap hot water heater are specialized, and when the correct site situation exists, MRC will use them again in an all-electric home. It is extremely unlikely that the mini-splits will get used again. Here is why: In a well- insulated home, cooling is not needed, but some will use the air conditioning if it is provided instead of managing the window opening. Much of the winter energy savings will be offset by the increased use in the summer months, defeating the purpose of striving for lower fuel consumption. The mini splits also require a fair amount of maintenance to run properly, not exactly a KISS strategy!

These two townhomes have other energy saving features: One home has a 1.55 KW PV system that will produce about 1500 kilowatt hours of electricity each year. The other home is pre-wired and has enough solar exposure to produce 4,000 kwh (kilowatt hours) per year. Both homes have induction cooking, which is 70% more efficient than gas. The final energy scores were 45 for the home with PV and 55 for the home without.

City Cabins at Columbia Station – sold in 2013

The New Rainier Vista is an urban renewal project built in South Seattle near the light rail train stop called Columbia Station. Martha Rose Construction built (4) high performance townhomes on the last lot of the 40 acre re-development. The units face south. These homes had a more affordable price tag, so some decisions were made to keep the pricing where it needed to be. The windows are triple glazed vinyl, with a U value of .21, the walls an R-28, the ceilings are an R-80 and the under-slab foam is an R-20.

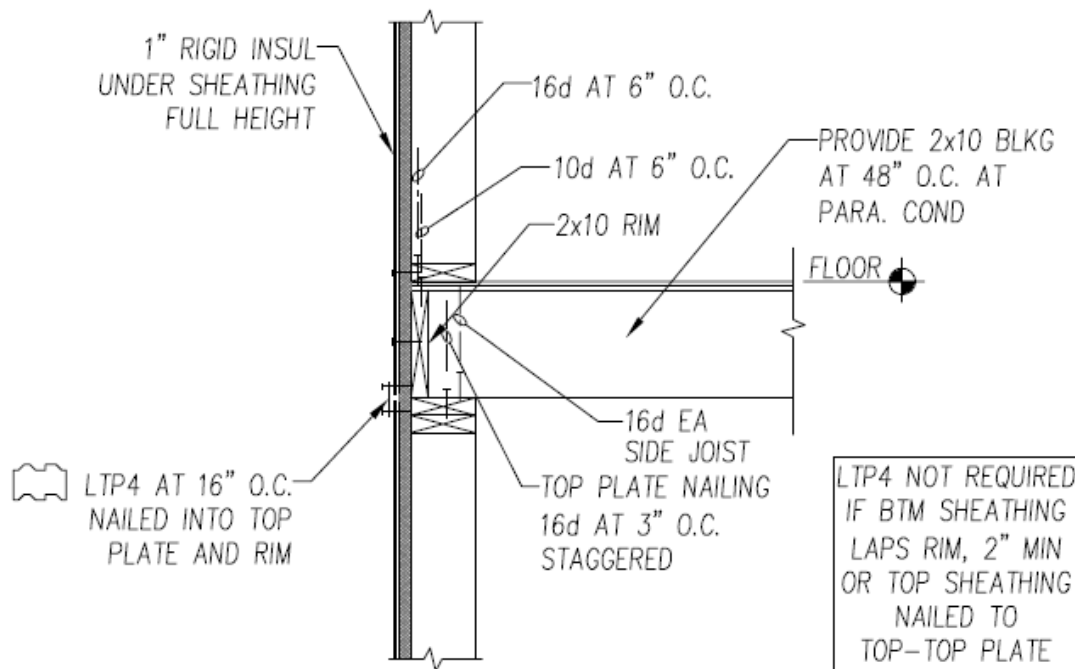

Plan detail showing closed cell foam sheets under cdx plywood on exterior wall

After consulting with our Building America Team, we decided to use Enerjoy InfraRed Heating Panels made by Solid State Heating Corporation in New York. They mount on the ceiling, and make no restrictions on furniture placement. Total heat needed was 3,000 watts for the three story, 2100 square foot homes.

The panels tend to blend in with the ceiling (white) and can be made almost any size with custom wattages and produce a very comfortable heat. Because the heat recovery ventilation system runs 24/7, the comfort level within the home is high. During an unusual 13 degree cold snap last winter one homeowner complained that the upper two floors were 68 degrees while the main floor was a less comfortable 64.

We are penalized for the electric resistance heat in our energy score, however a study conducted by NAHB and the Department of Energy actually found the Infra Red heating panels to use less energy than the minisplits and the homeowners claimed higher comfort. MRC will definitely use this type of heat in the future in all electric high performance homes.

The hot water solution was a bit more difficult in this grouping of 4 townhomes. The heat pump hot water heaters could not be used due to the requirements for outside walls and conditioned, not heated space. Our mechanical engineer suggested looking at the Seisco, an electric on-demand hot water heater. After many discussions with both the electrician and the plumber, we ended up installing both a tank and tankless hot water system in series. The incoming cold water is warmed by the ordinary electric hot water tank up to a temperature of about 80 degrees. Then the on demand tank warms it up to the final temperature of 115 or so. This system uses electricity more efficiently and allowed our electrical service panel to be one size smaller than what would have been required if we used just an on-demand water heater, but twice as large with more capacity. By preheating the water to just above room temperature, we have only nominal standby losses. The system also allows for flexibility. If a large family moves in, the preheat tank can be adjusted up. The 4 buyers have been quiet about hot water which is a good sign.

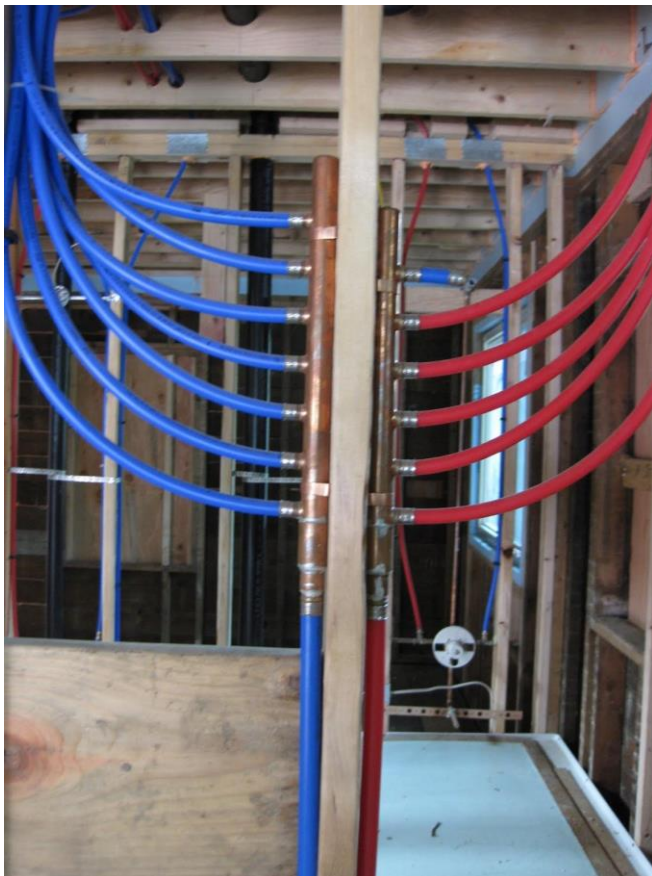

Typical Potable water distribution

Other energy efficient measures in these homes are the induction cooking range and 100% LED lighting.

City Cabins at Indian Wall – Start of construction is June 2014

The favorite take-aways from the last four projects will be the components that are used in this two unit project that will be completed and for sale in Spring of 2015. The site has excellent southern orientation and the shed roofs have been designed for a 10KW solar system to be installed on them. The future buyer will be able to add the panels at the point of sale when the homes are completed. The prewiring is a standard feature in all of the homes Martha Rose Construction builds.

The architect designed the oversized one-car garages as attached so that the AirTap hot water heaters could be used. The location of the hot water unit is in the garage directly adjacent to the plumbing core of the homes and there is an easy path to duct the cold air to an exterior wall. The volume of the garage is over 2,000 cubic feet which is double what is needed. The overhead and man doors are both insulated and the two garages of the two row-houses are sandwiched in between the two homes, so that there will be little heat loss from these garages. Keeping the garage temperature from getting too cold is necessary to get the highest efficiency from the heat pump hot water heater. A supply duct from the HRV will be providing continuous tempered air into the garage as well.

Insulation in the new homes will match the previous 4-unit project with R-28 walls, R-20 under slab foam, and attic insulation that is an R-76. Windows and doors will have a U-value of .21 The heat loads will be higher due to a Land Use Code for this site requiring 30% more windows than we would normally use, however they will still be considered high-performance home.

Ducoterra InfraRed panels, made in Washington State, will be used for heat in the two homes and a switch to Venmar heat recovery ventilators will be made. This change to new brands for heat and air flow, in no way reflects dissatisfaction with the prior brands. The new heating panels are made locally and are equally high quality and offer an even thinner profile of .5 inches thick. Since these two homes are 1750 square feet, the smaller Venmar AVS E15 ECM HRV offers adequate airflow volume and uses the high efficiency ECM motors. So even though the overall efficiency of the air exchanger is 75%, (lower than FanTech's 92%), the higher efficiency motors offset the slightly lower efficiency number.

Summary

Every climate zone and housing style may have different solutions for the optimum heating, cooling and ventilation equipment, however, the starting point is a good design and well insulated envelope. Through careful attention to air sealing and by increasing the quantity of insulation and the quality of the windows and doors, whatever heating method that may have been chosen in the past, can be greatly downsized, while retaining the most important feature that homeowners value – comfort.

AirTap Water Heater <http://www.airgenerate.com/>

Ducoterra Sola-Ray II Heating Panels <http://ducoterra.com/>

Enerjoy Heating Panels <http://www.sshcinc.com/>

DOE/NAHb Study of Heating Panels <http://www.sshcinc.com/PDF/EnerjoyCaseStudy.pdf>

Fantech 3005R HRV <http://www.fantech.net/enus/>

Mantis Fireplace <http://www.gas-space-heater.com/empire-mantis.html>

Mitsubishi Ductless Minisplit <http://www.mitsubishicomfort.com/en/consumer/product-solutions/product-showcase>

Paloma Gas Stove <http://www.heatnglo.com/Products/Paloma-Gas-Stove.aspx>

Seisco On-demand Electric Hot Water <http://www.seisco.com/>

Venmar HRV <http://www.venmar.ca/39-air-exchangers-e15-ecm-hrv-new.html#!prettyPhoto>

Vertex Hot Water Heater <http://www.aosmith.com/About/Detail.aspx?id=188>

Weather Resistant Acoustic Panels <http://www.soundproofcow.com/Water-Resistant-Panels/>
